



Department Of Public Health
& Environment

Food Service Establishment Construction Guide

TABLE OF CONTENTS

TABLE OF CONTENTS	2
1. PURPOSE	4
2. PLANS AND INSPECTIONS	5
A. Plans.....	5
B. Inspections.....	6
3. MENU	7
4. FACILITIES TO MAINTAIN PRODUCT TEMPERATURE	8
A. Sizing Refrigeration Units.....	8
B. Sizing Walk-In Refrigeration Units.....	8
C. Sizing Reach-In Refrigeration Units	9
D. Rail Refrigeration Units.....	10
E. Additional Requirements for Refrigerated Storage.....	10
5. FACILITIES TO PROTECT FOOD	11
6. EQUIPMENT	12
A. Installation.....	12
B. Table-Mounted Equipment	13
C. Floor-Mounted Equipment	14
D. Food Prep Area	14
E. Special equipment	15
F. Display equipment	15
G. Bar facilities	15
H. Beverage dispensing equipment.....	16
I. Wait Stations/Cabinetry	16
J. Clean-In-Place Equipment.....	17
7. ROOM AND AREA FINISHES	19
8. STORAGE FACILITIES	21
A. Space provided.....	21
B. Sizing a Dry Storage Room	21
C. Shelving	22
9. HANDWASHING FACILITIES	23
A. Number and Location	23
B. Water	23
C. Hand Washing Supplies	23
D. Prohibited Hand Washing Sinks.....	24
10. EMPLOYEE AREA	25
11. TOILET ROOMS	26
12. UTILITIES	27
A. Plumbing.....	27
B. Water Supply	27
C. Water Treatment Devices.....	28
D. Sewage Disposal.....	28
E. Cross-Connections/Backflow/Backsiphonage.....	29
F. Sanitary Installation of Utility Lines.....	30

13.	UTENSIL WASHING AND SANITIZATION.....	31
A.	Mechanical Warewashing.....	31
B.	Manual Warewashing.....	32
C.	Storage Area for Clean Equipment and Utensils.....	35
14.	SOLID WASTE AND RECYCLING MATERIALS	33
A.	Receptacles.....	33
B.	Interior Refuse Storage	33
C.	Exterior Refuse Storage	33
15.	LIGHTING.....	34
16.	INSECT AND RODENT CONTROL	35
17.	VENTILATION.....	36
A.	Make-Up Air.....	37
18.	MINNESOTA CLEAN INDOOR AIR ACT	38
INDEX.....		39

1. PURPOSE

The purpose of this guide is to provide assistance to owners, architects, food service consultants, equipment dealers and contractors in designing food service establishments which meet the Minnesota Food Code (Minnesota Rules Chapter 4626) and to answer commonly asked questions. Proper design will avoid errors, delays and prevent costly changes after construction has started. This is NOT a plan review, nor is it a comprehensive list of all regulations and requirements. Additional requirements may be stipulated after review of the proposed facility, menu, layout, equipment and site.

The use of commercial products and/or trade names are indicated “TM” and do not imply endorsement by the Washington County Department of Public Health and Environment nor bias against those not mentioned.

PLANS MUST BE RECEIVED BY WASHINGTON COUNTY AT LEAST 30 CALENDAR DAYS BEFORE CONSTRUCTION OR EXTENSIVE REMODELING BEGINS. IF PLANS ARE RECEIVED LESS THAN 30 CALENDAR DAYS BEFORE CONSTRUCTION OR EXTENSIVE REMODELING BEGINS, FIFTY PERCENT (50%) OF THE ORIGINAL PLAN REVIEW FEE WILL BE ASSESSED FOR A LATE FEE.

ALL PLANS AND EQUIPMENT SPECIFICATIONS SUBMITTED TO THE DEPARTMENT ARE CLASSIFIED AS PUBLIC DATA AS REGULATED BY MINNESOTA STATUTE, CHAPTER 13, SECTION 13.03

2. PLANS AND INSPECTIONS

A. Plans

1. The following items are required to be submitted to Washington County for review and approval:
 - a. The intended menu;
 - b. The anticipated volume of food to be stored, prepared, and sold or served;
 - c. The proposed layout, mechanical schematics, construction materials, and finish schedule;
 - d. The proposed equipment types, manufacturers, model numbers, locations, dimensions, performance capacities, and installation specifications;
 - e. Equipment specification sheets submitted as part of the plans must indicate that the equipment meets applicable National Sanitation Foundation International (N.S.F.) standards.
 - f. A complete set of elevations and drawings for all custom fabricated equipment;
 - g. A functional flow plan indicating how food will be handled;
 - h. Other information that may be required by Washington County for the proper review of the proposed construction, conversion, or modification.
 - i. A completed Plan Review Application Form;
 - j. A plan review fee that is equivalent to the annual license fee of the establishment.

PLANS THAT ARE INCOMPLETE WILL NOT RECEIVE APPROVAL. COMPLETE PLANS WILL BE REVIEWED WITHIN 30 DAYS OF RECEIPT.

2. If any changes are proposed after plans have been approved by this Department, additional plans with the proposed changes must be submitted for approval.
3. A variance may be requested from Minnesota Rules, Chapter 4626 except for the following: part 4626.0020, subpart 35; parts 4626.0040 to 4626.0060; 4626.0065 to 4626.0100; parts 4626.0105 to 4626.0120; part 4626.1565; parts 4626.1590 and 4626.1595; and parts 4626.1600 to 4626.1675. A fee is required for each variance request.
4. The proposed construction must conform to the Minnesota State Building, Plumbing, Mechanical, and Electrical Codes. The applicant must obtain all necessary permits and licenses for the establishment from the appropriate officials.

B. Inspections

1. An approved set of plans must be maintained at the construction site until final inspection and approval by Washington County. Representatives of Washington County may make on-site inspections of the facility construction, remodeling or equipment installation. **No field changes may be made to the establishment without approval from this Department.**
2. Pre-opening and final inspections are required before a license will be issued. Additional inspections or field consultations may be obtained by contacting Washington County at 651-430-6655 to schedule an inspection. The licensee or general contractor should contact Washington County at least 72 hours before the requested inspection time.

NO FOOD IS PERMITTED ON THE PREMISES UNTIL FINAL INSPECTION AND APPROVAL TO OPERATE HAS BEEN ISSUED BY WASHINGTON COUNTY. IT IS A VIOLATION OF THE WASHINGTON COUNTY FOOD CODE ORDINANCE TO OPERATE A FOOD SERVICE ESTABLISHMENT WITHOUT FIRST OBTAINING A LICENSE.

3. MENU

1. The menu is an integral part of the Plan Review process. The menu of a listing of all food and beverage items to be offered at the food service establishment must be submitted by the applicant to Washington County with the submission of all other Plan Review Application documents.
2. Food preparation processes will be evaluated during the plan review process. Submit to Washington County:
 - A. Type(s) of food to be served;
 - B. Volume of food to be served;
 - C. The style of food service (i.e., cook-to-order, self-service buffet, etc.);
 - D. A list of all food suppliers;
 - E. A list of all potentially hazardous foods;
 - F. A list of all complex foods, which would include the following:
 - a. Multiple ingredients being assembled or mixed;
 - b. Potentially hazardous foods;
 - c. Foods which will be prepared or held for several hours prior to service;
 - d. Foods requiring cooling and reheating;
 - e. Multiple step processing (foods that pass through the temperature danger zone of 41°F to 140°F more than once).

4. FACILITIES TO MAINTAIN PRODUCT TEMPERATURE

MECHANICAL REFRIGERATION IS REQUIRED TO MAINTAIN POTENTIALLY HAZARDOUS FOODS AT 41°F OR BELOW.

A. Sizing Refrigeration Units

1. Refrigeration facilities must be adequate to provide for the proper storage, transportation, display, and service of potentially hazardous foods. To plan for reserve storage, the following must be considered:
 - a. Menu
 - b. Type of Service
 - c. Number of Meals per Day
 - d. Number of Deliveries per Week
2. Point-of-use refrigerators should be provided at work stations for operations requiring preparation and handling of potentially hazardous foods.

B. Sizing Walk-In Refrigeration Units

1. The following formula is a *suggested* formula to establish required reserve storage (note: only 40% of a walk-in unit actually provides usable space):

$$\text{Total Interior Storage Volume Needed (ft}^3\text{)} = \frac{\text{Volume Per Meal (ft}^3\text{)} \times \text{Number of Meals}}{0.40}$$

Below are typical meal volumes for each of three types of refrigerated storage:

Meat, Poultry, Seafood:	0.010 – 0.030 ft ³ per meal
Dairy: 0.007	– 0.015 ft ³ per meal
Vegetables and Fruit:	0.020 – 0.040 ft ³ per meal

Thus, for a restaurant serving 1000 meals between deliveries (assume a minimum of 4 day storage), the following storage capacities are needed:

Meat refrigerated storage: $\frac{0.030 \text{ ft}^3 / \text{meal} \times 1000 \text{ meals}}{0.40} = 75 \text{ ft}^3$

Vegetable refrigerated storage: $\frac{0.040 \text{ ft}^3 / \text{meal} \times 1000 \text{ meals}}{0.40} = 100 \text{ ft}^3$

Dairy refrigerated storage: $\frac{0.015 \text{ ft}^3 / \text{meal} \times 1000 \text{ meals}}{0.40} = 37.5 \text{ ft}^3$

To calculate the interior storage space in square feet (ft²) required for the above example, divide the volume (ft³), in each case, by the height of the unit.

Example:

Meat refrigerated storage: $\frac{75 \text{ ft}^3}{6 \text{ ft}} = 12.5 \text{ ft}^2$

Vegetable refrigerated storage: $\frac{100 \text{ ft}^3}{6 \text{ ft}} = 16.67 \text{ ft}^2$

Dairy refrigerated storage: $\frac{37.5 \text{ ft}^3}{6 \text{ ft}} = 6.25 \text{ ft}^2$

To estimate total interior volume or space, add together the requirements for each type of food. The interior floor area would have to be 12.5 ft² + 16.67 ft² + 6.25 ft² = 35.42 ft² to accommodate refrigeration storage for 1000 meals. To convert interior floor area to exterior floor area, multiply the interior floor area by 1.25. Thus 1.25 x 35.42 ft² = 44.275 ft² would be needed. This number represents the actual amount of floor space the walk-in unit would occupy.

C. Sizing Reach-In Refrigeration Units

1. For reach-in refrigerators, the calculation is the same. However, the denominator is 0.75, since 75% of a reach-in unit actually provides usable space. So, using the same numbers above:

Meat refrigerated storage: $\frac{0.030 \text{ ft}^3 / \text{meal} \times 1000 \text{ meals}}{0.75} = 40 \text{ ft}^3$

Vegetable refrigerated storage: $\frac{0.040 \text{ ft}^3 / \text{meal} \times 1000 \text{ meals}}{0.75} = 53 \text{ ft}^3$

Dairy refrigerated storage: $\frac{0.015 \text{ ft}^3 / \text{meal} \times 1000 \text{ meals}}{0.75} = 20 \text{ ft}^3$

D. Rail Refrigeration Units

1. Refrigerated prep table and salad bar units must maintain potentially hazardous foods at 41°F or below

E. Additional Requirements for Refrigerated Storage

1. All refrigeration units must have a numerically scaled, integral or permanently affixed temperature measuring device that is accurate to $\pm 2^{\circ}\text{F}$ ($\pm 1^{\circ}\text{C}$). The device must be located in the warmest part of the unit.
2. Each walk-in unit must be equipped with lighting that provides at least 10 foot candles of light throughout the unit when the unit is full of product.
3. Condensate water from refrigeration units must be drained to a floor drain or an evaporator pan. Floor drains may not be inside of a walk-in refrigeration unit.

5. FACILITIES TO PROTECT FOOD

1. Adequate facilities must be provided to promote good hygienic practices, sanitary food handling and to minimize the potential of cross-contamination between ready-to-eat foods and raw product.
2. It is highly recommended that a separate food preparation area is provided for handling, washing and preparing raw meat, fish, and poultry, if served. Where portable cutting boards are planned, they should be color coded or labeled for specific use.
3. All food being displayed, served, or held must be adequately protected from contamination by the use of: packaging; serving line, storage or salad bar protector devices; display cases; or by other effective means, including dispensers.
4. Salad bars and sneeze guards must comply with the National Sanitation Foundation (N.S.F.) Standard No. 2. The food shield should intercept the direct line between the customer's mouth and the food on display. On average, the vertical distance from the customer's mouth to the floor is between 4'6" to 5' as shown in Figure 1. This average must be adjusted for children in educational institutions, and for other special considerations, such as to accommodate the wheel chair bound.

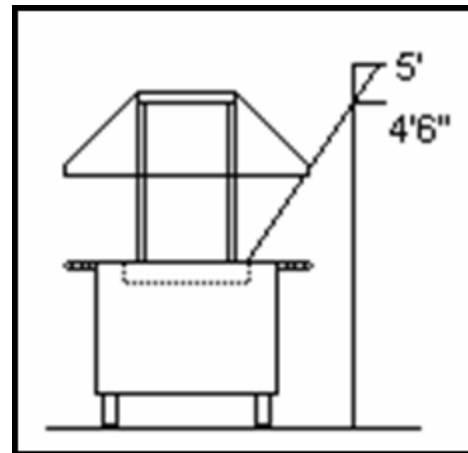

Figure 1

6. EQUIPMENT

A. Installation

1. The equipment shall be determined to meet applicable NSF standards by: NSF International; or, an American National Standards Institute (ANSI) Z34.1 accredited independent entity, including Underwriters Laboratory (UL) or the Edison Testing Laboratory (ETL).



ALL FOOD SERVICE EQUIPMENT MUST HAVE THE NSF SEAL AT THE TIME OF INSPECTION. EQUIPMENT INSTALLED THAT DOES BEAR THE NSF SEAL MUST BE REPLACED OR FIELD INSPECTED BY NSF. IF A PIECE OF EQUIPMENT LEAVES THE FACTORY WITHOUT AN NSF SEAL, NO PERSON OTHER THAN AN NSF AUTHORIZED PERSON MAY PLACE THE NSF SEAL A PIECE OF EQUIPMENT.

2. Used equipment must be inspected and approved by Washington County before use.
 - a. Standard No. 2, Food Equipment, 1996 and subsequent editions;
 - b. Standard No. 3, Commercial Spray-Type Dishwashing and Glasswashing Machines, 1996 and subsequent editions;
 - c. Standard No. 4, Commercial Cooking, Rethermalization, and Powered Hot Food Holding and Transport Equipment, 1996 and subsequent editions;
 - d. Standard No. 5, Water Heaters, Hot Water Supply Boilers, and Heat Recovery Equipment, 1992 and subsequent editions;
 - e. Standard No. 6, Dispensing Freezers, 1996 and subsequent editions;
 - f. Standard No. 7, Food Service Refrigerators and Storage Freezers, 1990 and subsequent editions;
 - g. Standard No. 8, Commercial Powered Food Preparation Equipment, 1992 and subsequent editions;
 - h. Standard No. 12, Automatic Ice Making Equipment, 1992 and subsequent editions;
 - i. Standard No. 13, Refuse Compactors and Compactor Systems, 1992 and subsequent editions;

- j. Standard No. 18, Manual Food and Beverage Dispensing Equipment, 1996 and subsequent editions;
- k. Standard No. 20, Commercial Bulk Milk Dispensing Equipment, 1992 and subsequent editions;
- l. Standard No. 25, Vending Machines for Food and Beverages, 1990 and subsequent editions;
- m. Standard No. 26, Pot, Pan, and Utensil Commercial Spray-Type Washing Machines, 1990 and subsequent editions;
- n. Standard No. 29, Detergent and Chemical Feeders for Commercial Spray-Type Dishwashing Machines, 1992 and subsequent editions;
- o. Standard No. 35, Laminated Plastics for Surfacing Food Service Equipment, 1991 and subsequent editions;
- p. Standard No. 51, Plastic Materials and Components Used in Food Equipment, 1978 and subsequent editions;
- q. Standard No. 59, Food Carts, 1986 and subsequent editions;
- r. Criteria C-2, Special Equipment and Devices, 1983 and subsequent editions;

B. Table-Mounted Equipment

1. Table-mounted equipment that is not easily movable must be installed to allow cleaning of the equipment and areas underneath and around the equipment by being:
 - a. Sealed to the table;
 - b. Elevated on legs that provide at least a four (4)-inch clearance between the table and the equipment;
 - c. Elevated on legs that provide at least a three (3)-inch clearance between the table and the equipment if the horizontal distance of the table top under the equipment is no more than twenty (20) inches from the point of access for cleaning; or
 - d. Elevated on legs that provide at least a two (2)-inch clearance between the table and the equipment if the horizontal distance of the table top under the equipment is no more than three (3) inches from the point of access for cleaning.

C. Floor-Mounted Equipment

1. Floor-mounted equipment that is fixed because it is not easily movable must be installed so that it is:
 - a. Spaced to allow access for cleaning along the sides of, behind, and above the unit;
 - b. Spaced from adjoining equipment, walls, and ceilings at a distance of not more than 1/32 inch (one millimeter);
 - c. Sealed to adjoining equipment or walls, if the unit is exposed to spillage or seepage;
 - d. Sealed to the floor (if designed for such installation); or
 - e. Elevated on legs that provide at least a six (6)-inch clearance between the floor and the equipment; or
 - f. Elevated on legs that provide at least a four (4)-inch clearance between the floor and the equipment if no part of the floor under the floor-mounted equipment is six (6) inches from the point of cleaning access; or
 - g. Installed with casters, rollers, or gliders to permit the unit to be easily moved by one (1) person.

ENCLOSED HOLLOW BASES ARE NOT PERMITTED.

D. Food Prep Area

1. If the menu has products that require washing and/or thawing, a separate food preparation sink must be provided. The number of compartments is as follows:
 - a. One Compartment Food Prep Sink: if **either** the thawing of meat **or** the washing of fruits and vegetables is necessary.
 - b. Two Compartment Food Prep Sink: if **both** the thawing of meat **and** the washing of fruits and vegetables is necessary.
2. An integral drainboard should be provided on the food prep sink for each basin.

E. Special equipment

1. Custom equipment must be constructed by a manufacturer or fabrication company listed by NSF.
2. Dipperwells, with running water, are required when ice cream is dispensed. A dipperwell may also be required for other moist foods, such as mashed potatoes, if the scoop is not stored in the food. The dipperwell should be located adjacent to the proposed area of use. The dipperwell must have an indirect connection to the building sewer.

F. Display equipment

1. Salad bars must be provided with mechanical refrigeration to maintain any potentially hazardous foods at 41°F or below. Food guards, or “sneeze shields”, must be provided at the salad bar or buffet, as shown in Figure 2. An approved floor surface must be provided directly beneath, and three (3) feet beyond all open sides of, the salad bar or buffet.

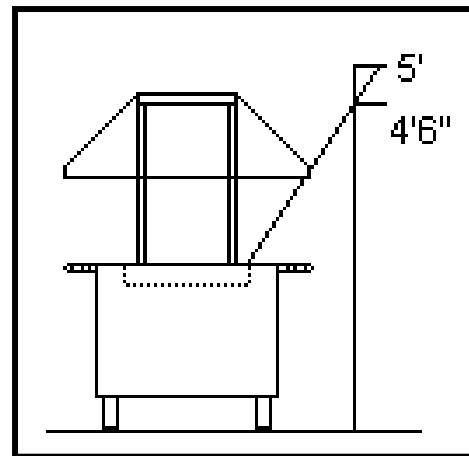

Figure 2

G. Bar facilities

1. At least one handwashing sink is required in the bar and must be equipped with a fingernail brush, hand soap and single-use hand towels with a dispenser.
2. A four compartment sink may be used in the bar for glass washing and hand washing.
3. Utility service lines for the water supply, waste water plumbing, and electricity for the bar must not be unnecessarily exposed and installed so as to not obstruct or prevent cleaning of the floors, walls, and ceilings. Utility lines must not be installed directly on the walls or floors.
4. All interior surfaces of the bar, including the underside of the bar-top, must meet the same finish requirements as the walls of the kitchen.
5. If wood is to be used as the bar-top, it should be a hard-wood, such as maple or oak, and be finished with a minimum of three coats of polyurethane.
6. All food service equipment in the bar must meet applicable N.S.F. International standards.

H. Beverage dispensing equipment

1. Equipment that dispenses liquid or ice in an unpackaged form must meet the following requirements:
 - a. The delivery tube, chute, orifice, and splash surfaces directly above the container receiving the food shall be designed with barriers, baffles, drip aprons, or similar devices to divert drips from condensation and splash from the opening of the container receiving the food;
 - b. The delivery tube, chute, and orifice shall be recessed or otherwise protected from manual contact;
 - c. The delivery tube or chute and orifice of equipment used to vend to self-service consumers shall be designed so that the delivery tube or chute and orifice are protected from dust, insects, rodents, and other contamination by a self-closing door if the equipment is:
 - i. located in an outside area that does not otherwise afford the protection of an enclosure against rain, windblown debris, insects, rodents, and other contaminants that are present in the environment; or
 - ii. available for self-service during hours when it is not under the full-time supervision of a food employee; and
 - d. The dispensing equipment actuating lever or mechanism and filling device of consumer self-service beverage dispensing equipment shall be designed to prevent contact with the lip-contact surface of glasses or cups that are refilled.

I. Wait Stations/Cabinetry

1. Custom fabricated cabinets used in the wait station, bars, or customer self service area must be finished with plastic laminate that meets NSF Standard No. 35. All exposed surfaces of the cabinet(s), including the underside of the cabinet, must be finished with plastic laminate. If food is to be prepared directly on the work surface of the wait station, a stainless steel top that meets N.S.F. Standard No. 2 must be provided.

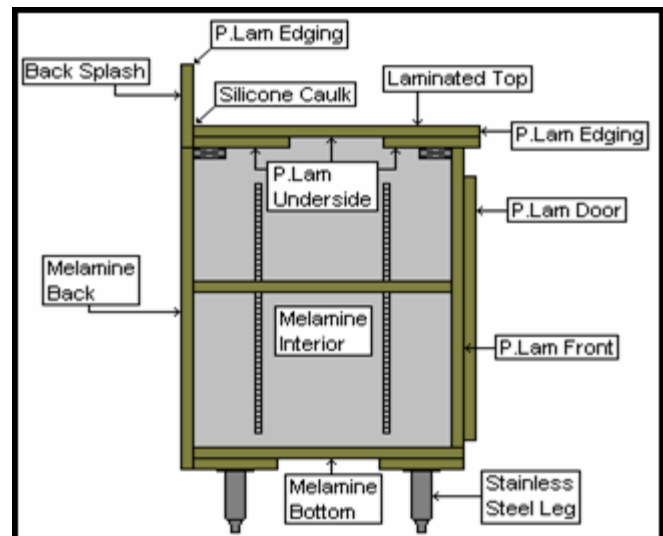

Figure 3

2. Cut outs in the millwork must be sealed by the fabricator.

Cabinet/Counter Construction

Equipment Type	Laminated Top Laminated Base	Stainless Top Laminated Base	Stainless Top Metal Base
Coffee	Yes	Yes	Yes
Milk	Yes	Yes	Yes
Soda	Yes (2)	Yes	Yes
Ice Bins	Yes (1)	Yes (1)	Yes
Hand Sink	Yes (1, 2)	Yes (1)	Yes
Glass Racks	Yes	Yes	Yes
Cold Drop-In	Yes (1, 2)	Yes (1)	Yes
Hot Drop-In	Yes (1)	Yes (1)	Yes
Display Merchandiser (Popcorn, Pizza)	Yes	Yes	Yes
Drawer Warmer	Yes	Yes	Yes
Counter Top Warmer (Soup, Sauces)	Yes	Yes	Yes
Slicers	No	Yes	Yes
Blenders	No	Yes	Yes
Cutting Boards	No	Yes	Yes
Cooking Equipment (Fryer, Grill, Hot Plate, Waffle Iron)	No	No	Yes
Food Processor, Mixer, Chopper	No	No	Yes
Toaster (Self-Service)	Yes	Yes	Yes
Sinks/Dishwashing	No	No	Yes
Microwave	Yes	Yes	Yes
Refrigerator/Freezer	Yes	Yes	Yes

Table 1

- (1) Omit Cabinet Floor
- (2) Customer Service Area Only

J. Clean-In-Place Equipment

1. Clean-In-Place (CIP) equipment shall be:
 - a. Smooth;
 - b. Free of breaks, open seams, cracks, chips, pits and similar imperfections;
 - c. Free of sharp internal angles, corners and crevices;
 - d. Finished to have smooth welds and joints; and,
 - e. Accessible for cleaning and inspection by one of the following methods:
 - i. without being disassembled;
 - ii. by disassembling without the use of tools; or
 - iii. by easy disassembling with the use of hand-held tools commonly available to maintenance and cleaning personnel, including screwdrivers, pliers, open-end wrenches, and allen wrenches.

2. CIP equipment must be designed and constructed so that:
 - a. Cleaning and sanitizing solutions circulate throughout a fixed system and contact all interior food-contact surfaces; and
 - b. The system is self-draining or capable of being completely drained of cleaning and sanitizing solutions.
3. CIP equipment that is not designed to be disassembled for cleaning shall be designed with inspection access points to ensure that all interior food-contact surfaces throughout the fixed system are effectively cleaned.
4. CIP equipment should be located in close proximity to a floor drain or floor sink to prevent flooding while emptying the equipment of water.

7. ROOM AND AREA FINISHES

1. Indoor floor, wall, and ceiling surfaces under conditions of normal use must be:
 - a. Smooth, durable, and easily cleanable for areas where food establishment operations are conducted; and
 - b. Non-absorbent for food preparation areas, walk-in refrigerators, warewashing areas, toilet rooms, janitorial areas, laundry areas, interior garbage and refuse storage rooms, areas subject to flushing or spray cleaning methods, and other areas subject to moisture.
2. The following is a table indicating different in a food service establishment, and the room finishes that are approved.

Room and Area Finishes

Table 2

Area	Floor								Walls						Ceiling							
	Stainless Steel	Diamond Plate Aluminum	Quarry Tile	Commercial Vinyl Tile	Terrazzo	Commercial Epoxy Resin(2)	Sealed Concrete	Ceramic Tile (5)	Stainless Steel	Aluminum (Smooth)	Ceramic Tile	FRP	Epoxy Painted Drywall	Filled Block w/Epoxy	Semi-Gloss Painted Drywall	Stainless Steel	Aluminum (Smooth)	Semi-Gloss Painted Drywall	FRP	Ceramic Tile	Commercial Vinyl Sheetrock	
Food Prep Area	X		X		X	X		X	X	X	X			X		X	X	X	X	X		
Cooking Area	X		X		X	X		X	X	X				X		X	X	X	X	X		
Walk-In Refrigeration Unit	X		X		X				X	X						X	X					
Beer Cooler	X	X	X		X				X	X						X	X					
Toilet Room	X		X	X	X			X	X	X	X		X	X	X(3)	X	X	X	X	X		
Mop Sink	X		X		X	X		X	X	X	X			X		X	X	X	X	X		
Interior Refuse Storage	X		X	X	X	X	X	X	X	X	X			X		X	X	X	X	X		
Wait Station	X		X	X	X			X	X	X	X		4	X	4	X	X	X	X	X		
Handwash	X		X	X	X			X	X	X	X			X		X	X	X	X	X		
Bar	X		X		X	X		X	X	X	X		X(1)	X		X	X	X	X	X		
Dry Storage Room	X		X	X	X			X	X	X	X		X	X	X	X	X	X	X	X		
Other Storage	X		X	X	X	X	X	X	X	X	X		X	X	X	X	X	X	X	X		
Warewashing	X		X		X	X		X	X	X	X			X		X	X	X	X	X		

- 1 Drywall may be used in bars only in areas that are greater than 18-inches from a moisture source.
- 2 Commercially applied epoxy resin consisting of at least two initial coats and a finish at least 13/64" thick. Must extend at least four inches up walls to form an integral coving. Material specifications must be submitted for review prior to installation.
- 3 Not acceptable near plumbing
- 4 Depends on location and services provided
- 5 Submit sample for approval

SAMPLES OF FINISH MATERIALS OTHER THAN THOSE LISTED IN TABLE 1 MUST BE SUBMITTED TO WASHINGTON COUNTY FOR CONSIDERATION.

3. The floor and wall junctures must be covered with a material consistent with the floor material. Coving tile must be installed with the toe of the coving tile flush with the floor, as shown in Figure 4.

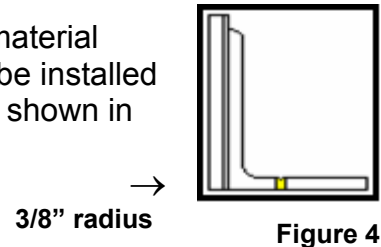

4. Carpeting or similar material must not be installed as a floor covering in food preparation areas; walk-in refrigerators or freezers; warewashing areas; toilet room areas where handwashing lavatories, toilets and urinals are located; refuse storage areas; wait stations; dressing rooms; locker rooms; janitorial areas; within three feet around permanently installed bars and salad bars, other food service equipment, and food storage rooms; or other areas subject to moisture, flushing, or spray cleaning methods.
5. If carpeting is installed as a floor covering in areas other than those specified above, the carpet must be securely attached to the floor with a durable mastic; and, installed tightly against the wall under the coving or installed away from the wall with a space between the carpet and the wall and with the edges of the carpet secured by metal stripping or some other means.
6. Mats and duckboards must be constructed of non-absorbent, non-wood, grease-resistant materials.
7. Throw carpeting may be used at the customer entrance.
8. Studs, joists and rafters may be exposed in areas used exclusively for the storage of food and single-use articles in unopened packages.

8. STORAGE FACILITIES

A. Space provided

1. The dry storage space required depends on the menu, number of meals, quantities purchased and frequency of deliveries. The location of the storeroom should be adjacent to the food preparation area and convenient to receiving. Where possible, the storeroom should be free of uninsulated steam and water pipes, water heaters, transformers, refrigeration condensing units, steam generators or other heat generating equipment. Temperatures of 50°F to 80°F and a relative humidity of less than 50% are recommended. Foods shall not be stored:
 - a. In a locker room;
 - b. In a toilet room
 - c. In a dressing room;
 - d. In a garbage room;
 - e. In a mechanical room;
 - f. Under a sewer line that is not shielded to intercept potential drippings;
 - g. Under a leaking water line, including a leaking automatic fire sprinkler head, or under a line on which water has condensed;
 - h. Under an open stairwell; or
 - i. Under any source of contamination.

B. Sizing a Dry Storage Room

1. Two *suggested* formulas are used in estimating required storage space:

$$\text{Linear Feet of Shelving} = \frac{\text{Volume per Meal} \times \text{Number of Meals Between Deliveries}}{D \times H \times C}$$

Formula #1

- D = Depth of the shelves in feet
- H = Clearance of shelves in feet
- C = 80% effective capacity of shelf height

For example, assume 400 meals per day and a 10 day storage between deliveries. This equals 4000 meals for which to provide storage. Volume per meal is 0.035 ft³, shelf depth of 18 inches (1.5 ft), clearance of 18 inches (1.5 ft) between shelves, and 80% effective capacity of shelf height. For the calculation, 80% = 0.80.

$$\text{Linear Feet of Shelving for Storage} = \frac{0.035 \text{ ft}^3 \times 4000 \text{ meals}}{1.5 \text{ ft} \times 1.5 \text{ ft} \times 0.80} = 77.77 \text{ Linear Feet}$$

Formula #2

$$\text{Required Storage Area (ft}^2\text{)} = \frac{\text{Volume per Meal} \times \text{Number of Meals Between Deliveries}}{\text{Average Height} \times \text{Fraction of Usable Storeroom Floor Area}}$$

- Volume per meal = 0.025 ft³ to 0.050 ft³ per meal served
- Useful storage height = 4 to 7 feet
- Storage time between deliveries = 3 to 14 days
- Fraction of useable storeroom floor area = 30% to 60%

Using the example above, assuming a storage height of 5 feet and a usable storeroom floor area of 50%:

$$\text{Required Storage Area (ft}^2\text{)} = \frac{0.035 \text{ ft}^3 \times 4000 \text{ meals}}{5 \text{ ft} \times 0.50} = 56 \text{ ft}^2$$

So, the dry storage room would have to have an area of at least 56 square feet to accommodate the dry storage requirements of this establishment.

C. Shelving

1. Shelving, dunnage racks, and other equipment used for storage shall be constructed to meet NSF Standard No. 2.

9. HANDWASHING FACILITIES

A. Number and Location

1. At least one dedicated hand washing sink must be provided in each work area in the establishment where food and beverages are handled.
2. Hand washing sinks must be located to allow convenient use by employees in food preparation, food dispensing, and warewashing areas.
3. At least one hand washing sink must be provided in each toilet room.
4. Bars must have at least one hand washing sink.
5. If unpackaged food and/or clean equipment and utensils are in close proximity to a hand washing sink, the food and equipment must be protected from splash from the hand sink by use of splash shields.

B. Water

1. Each hand washing sink must provide water at a temperature of at least 110°F through a mixing valve or a combination faucet.
2. Self-closing, slow-closing, or metering faucets must provide a flow of water for at least 15 seconds without the need to reactivate the faucet.

C. Hand Washing Supplies

1. Each hand washing sink must be provided with:
 - a. A supply of hand cleaning liquid, or foam;
 - b. A nailbrush;
 - c. A hand drying provision, which includes:
 - i. Individual, disposable towels;
 - ii. A continuous towel system that supplies the user with a clean towel; or
 - iii. A heated-air hand dryer. The heated-air hand dryer may not be the only hand drying device provided at a hand washing sink used by employees in a food preparation area or warewashing area.
2. A waste receptacle must be provided for each hand washing sink that is provided with individual, disposable towels.

D. Prohibited Hand Washing Sinks

1. A sink used for food preparation or utensil washing, or a service sink or curbed cleaning facility used for the disposal of mop water, or similar wastes, must not be used as a hand washing sink and must not be provided with the hand washing aids described above.

10. EMPLOYEE AREA

1. Dressing rooms or dressing areas must be designated if employees routinely change clothes in the establishment.
2. Lockers, or other suitable facilities, must be provided for the orderly storage of employees' clothing and other possessions and be located in a designated room or area where contamination of food, equipment, utensils, linens, and single-service and single-use articles cannot occur.
3. Areas designated for employees to eat and drink must be located so that food, equipment, linens, and single-service articles are protected from contamination.

11. TOILET ROOMS

1. At least one toilet, or the number of toilets required by the Minnesota Plumbing Code, must be provided for use by employees. In accordance with the Minnesota Plumbing Code, urinals may be substituted for toilets if more than the required minimum number of toilets is provided.
2. A toilet room must be completely enclosed and provided with a tight-fitting and self-closing door.
3. Each restroom must be provided with a covered waste receptacle for the disposal of sanitary napkins and diapers.

12. UTILITIES

A. Plumbing

1. A plumbing system conveying water and/or sewage must be designed, constructed and installed according to the Minnesota Plumbing Code (Minn. Rules Chapter 4715). Plumbing plans must be submitted to the Minnesota Department of Labor and Industry for review and approval. Plumbing plans must be addressed to:

Minnesota Department of Labor and Industry
Plumbing and Engineering
443 Lafayette RD N
St. Paul, MN 55155-4343
Phone: (651) 284-5067
Fax: (651) 284-5748

B. Water Supply

1. Drinking water must be obtained only from an approved public water main regulated under the Public Water Supply Code (Minn. Rule Chapter 4720) or a drinking water well drilled and constructed in accordance with the Well Code (Minn. Rule 4725) and Minnesota Statute 31.175.
2. Food service establishments that use a private drinking water well and are located in a special well construction area must have the well tested for volatile organic compounds (VOCs) before the well is in service.
3. All materials used in a drinking water supply system must comply with the Minnesota Plumbing Code.
4. A drinking water system must be flushed and disinfected before being placed into service after construction, repair or modification.
5. The water source and system must be of sufficient capacity to meet the water demands of the food establishment.
6. Drinking water must be provided under pressure to all fixtures in the establishment.
7. Private drinking water wells at food establishments must be tested for nitrate-nitrogen and coliform bacteria prior to opening and then annually.
8. A sanitary well survey must be conducted prior to opening.
9. Hot water generating equipment and distribution systems must be sufficient to meet the peak hot water demands throughout the food establishment.

10. Non-drinking water must only be used for air conditioning, non-food equipment cooling, fire protection, irrigation, and other non-culinary purposes. The piping of a non-drinking water supply must be durably identified so that it is readily distinguishable from piping that carries drinking water. A connection between the drinking water supply and a non-drinking water supply, or other water supply of unknown quality, is prohibited.

C. Water Treatment Devices

1. Water treatment systems must meet applicable National Sanitation Foundation standards:
 - a. Standard No. 42, Drinking Water Treatment Unit - Aesthetic Effects, 1988 and subsequent editions;
 - b. Standard No. 44, Cation Exchange Water Softeners, 1987 and subsequent editions (*Note: this is a residential standard*);
 - c. Standard No. 53, Drinking Water Treatment Units – Health Effects, 1996 and subsequent editions; or
 - d. Standard No. 58, Reverse Osmosis Drinking Water Systems, 1996 and subsequent editions.
2. Water filters, screens or other water conditioning devices must be conveniently installed on a water line to facilitate disassembly for periodic servicing and cleaning.
3. A water treatment device, other than a water softener, must be scheduled for inspection and service according to the manufacturer's instructions and as necessary to prevent device failure based on local water conditions.

D. Sewage Disposal

1. Sewage must be disposed of through a public sewage treatment plant or an individual sewage treatment system (ISTS) that is sized, constructed, maintained and operated according the Washington County Development Code, Chapter 4, Individual Sewage Treatment Regulations (Ordinance No. 128) and the Minnesota Individual Sewage Treatment System Standards (Minn. Rules Chapter 7080 and 7081).
2. Food service establishments that use an individual sewage treatment system (ISTS) must submit the ISTS plans and specifications to our Department for review and approval prior to installation.
3. At least one service sink or one curbed cleaning facility equipped with a floor drain must be provided and conveniently located for cleaning mops or similar wet floor cleaning tools and for disposal of mop water and similar liquid

wastes. The service sink or cleaning facility must include a faucet accessible for supply of drinking water.

4. An indirect waste connection must be installed for a cold storage room, refrigerator, cooling counter, compartment, receptacle, appurtenance, or device which is used, designed, or intended to be used for the storage or holding of food or drink. This includes, but not limited to, refrigeration units, ice bins, dipperwells, and steam tables.
5. Floor drains must not be located inside of a walk-in cooler and/or freezer.
6. A floor drain is required for bars which have a 3 compartment sink.
7. If the local municipality requires a grease trap to be installed, the grease trap must be located to be easily cleanable and be installed with the lid flush with the floor.

E. Cross-Connections/Backflow/Backsiphonage

1. A cross-connection is defined as any connection or structural arrangement between a potable water supply and a non-potable water source, liquid or otherwise, through which backflow can occur.
2. A connection between the drinking water supply and a non-drinking water supply, or other water supply of unknown quality, is prohibited.
3. Backflow is defined as the flow of water or other liquids, mixtures, or substances into a potable water supply from any source, other than the intended source.
4. A plumbing system must be installed to preclude backflow of a solid, liquid or gaseous contaminant into the drinking water supply at each point of use by:
 - a. Providing an air gap; or
 - b. Installing an approved backflow prevention device.

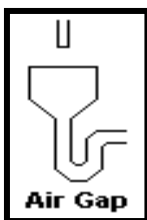

Figure 5

5. An air gap between the water supply inlet and the flood level rim of the plumbing fixture, equipment, or non-food equipment must be at least twice the diameter of the water supply inlet and must not be less than 1-inch (25 mm).
6. An air gap means the unobstructed vertical distance through the free atmosphere between the lowest opening from any pipe or

outlet supplying fixture, or other device, and the flood level rim of the receptacle. An air gap must be provided if the supply line is part of a pressurized water supply, such as a sink faucet, spray rinse arm, etc.

7. An air break is a piping arrangement in which a drain from a fixture, appliance, or device discharges indirectly into another fixture, receptacle or interception at a point below the flood level rim. The connection does not provide an unobstructed vertical distance through the free atmosphere, like an air gap, and is not solidly connected, but precludes the possibility of backflow to the potable water supply into a sink or dishwasher or fixture being drained. An air break may be provided, rather than an air gap, if the line is not connected to a pressurized water supply, therefore, backsiphonage cannot occur. Examples of drainlines that could use an air break include an ice bin drainline, dipperwell, or condensate drainage.

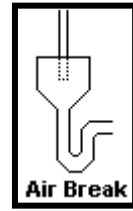

Figure 6

8. A backflow or backsiphonage device installed on a water supply system must meet American Society of Sanitary Engineering Standards for construction, installation, maintenance, inspection, and testing for that specific application and type of device.
9. The backflow prevention device must be located so that it may be serviced or maintained.
10. Post-mix carbonated beverage machines must have a backflow prevention device between the pump and the carbonator.
11. A control valve may not be installed downstream from an atmospheric vacuum breaker. This includes spray nozzles and spray rinse arms.

F. Sanitary Installation of Utility Lines

1. Utility service lines and pipes must not be unnecessarily exposed.
2. Exposed utility service lines and pipes must be installed so they do not obstruct or prevent cleaning of the floors, walls, or ceilings.
3. Exposed utility service lines and pipes must not be installed directly on the walls or floor, except:
 - a. Quick disconnect gas hoses approved by the American Gas Association or NSF International; and
 - b. Flexible cords and caps for commercial cooking equipment on casters.

13. UTENSIL WASHING AND SANITIZATION

A. Mechanical Warewashing

1. Dishwashers must discharge to the sewage system through an air break. *If a floor drain constructed without a backwater valve is installed on the horizontal dishwasher branch, the dishwasher may be connected directly to the sewage system, as shown in the illustration on the right.* The water supply to a dishwasher in which the supply opening is below the spill rim of the machine must be protected with a backflow prevention device.

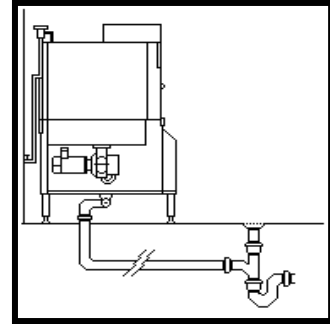

Figure 7

2. Warewashing machines that provide a fresh hot water sanitizing rinse must be equipped with a pressure gauge, transducer, or similar device that measures and displays the water pressure in the supply line immediately before entering the warewashing machine.
3. If the flow pressure measuring device is upstream of the fresh hot water sanitizing rinse control valve, the device must be mounted in a 1/4-inch (64mm) iron pipe size (IPS) valve.
4. Pressure measuring devices that display the pressure in the water supply line for the fresh hot water sanitizing rinse must have increments of 1 pound per square inch (PSI) (7 kPa) and must be accurate to 2 PSI (14 kPa) in the 15 to 25 PSI (100-170 kPa) range.
5. A warewashing machine must be provided with an easily accessible and readable data plate affixed to the machine by the manufacturer that indicates the machine's design and operating instructions, including:
 - a. Temperatures required for washing, rinsing and sanitizing;
 - b. Pressure required for the fresh water sanitizing rinse; and
 - c. Conveyor speed for the conveyor machines or cycle time for stationary rack machines.
6. Warewashing machine wash and rinse tanks must be equipped with baffles, curtains, or other means to minimize internal cross-contamination of the solutions in wash and rinse tanks.
7. Warewashing machines must be equipped with a temperature measuring device accurate to $\pm 3^{\circ}\text{F}$ that indicates the temperature of the water in each wash and rinse tank and as the water enters the hot water sanitizing final rinse manifold or in the chemical sanitizing solution tank.

8. Warewashing machines that use a chemical for sanitization must be equipped with a device that indicates audibly or visually when more chemical sanitizer needs to be added.
9. Hot water sanitizing machines must have space for a minimum of three (3) racks for drying dishes/utensils.
10. Chemical sanitizing machines must have space for a minimum of five (5) racks for drying dishes/utensils.
11. Type II ventilation hoods and sufficient make-up air must be installed over a high-temp or low-temp warewashing machine. Under counter dishwashers do not need to be provided with a ventilation hood.

B. Manual Warewashing

1. A three compartment sink is required for all food service establishments. A mechanical warewashing machine may also be provided in addition to the three compartment sink.
2. The three compartment sink provided for manual washing, rinsing and sanitizing equipment and utensil must have integrally attached, self draining drainboards at each end. Drainboards must be large enough to accommodate all soiled and cleaned items that may accumulate during hours of operation.

C. Storage Area for Clean Equipment and Utensils

1. Space must be provided for the storage of clean equipment and utensils.
2. Clean equipment and utensils must be stored:
 - a. In a clean, dry location
 - b. Where they are not exposed to splash, dust, or other contamination
 - c. At least six (6) inches above the floor
3. Clean equipment and utensils must not be stored:
 - a. In a locker room
 - b. In a toilet room
 - c. In a garbage room
 - d. In a mechanical room
 - e. Under a sewer line that is not shielded to intercept potential drips
 - f. Under a leaking water line including a leaking automatic fire sprinkler head or under a line on which water has condensed
 - g. Under an open stairwell
 - h. Under any other source of contamination

14. SOLID WASTE AND RECYCLING MATERIALS

A. Receptacles

1. Receptacles for refuse, recyclables and returnables must be durable, cleanable, insect and rodent-resistant, leak-proof and non-absorbent.
2. Receptacles for refuse, recyclables and returnables and used outside the food establishment must be designed and constructed to have tight-fitting lids, doors and covers.

B. Interior Refuse Storage

1. A refuse storage area located within the establishment must have floor, wall and ceilings constructed of materials specified in Table 2 on page 20 of this document.
2. A receptacle must be provided in each area of the food establishment or premises where refuse is generated or commonly discarded.
3. If disposable towels are used at a handwashing sink, a waste receptacle must be provided.
4. Toilet rooms must be provided with a covered receptacle for the disposal of sanitary napkins or diapers.
5. An interior refuse storage area, if used, must be of sufficient capacity to hold refuse, recyclables and returnables in a manner in which a nuisance or public health hazard is not created.

C. Exterior Refuse Storage

1. An outdoor storage surface for refuse, recyclables and returnables must be constructed of concrete, asphalt, or other non-absorbent material and must be smooth, durable, and sloped to drain.
2. If used, an outdoor enclosure for refuse, recyclables and returnables must be constructed of durable and cleanable materials.
3. Refuse, recyclables and returnables must be stored in receptacles so that they are not accessible to insects and rodents.
4. Drains in exterior refuse, recyclable and returnable receptacles must be provided with drain plugs.

15. LIGHTING

1. The intensity of light must be:

- | | |
|-----------------|--|
| 10 foot candles | <ul style="list-style-type: none">• Walk-in refrigeration units, dry storage rooms, other areas and rooms during periods of cleaning. |
| 20 foot candles | <ul style="list-style-type: none">• At a surface where food is provided for consumer self-service, including buffets and salad bars, or where fresh produce or packaged foods are sold or offered for consumption• Inside equipment including reach-in and under-counter refrigerators.• Areas used for equipment and utensil storage.• Toilet rooms. |
| 50 foot candles | <ul style="list-style-type: none">• At a surface where food employees are working with food or working with utensils or equipment, including knives, slicers, grinders, or saws.• Where employee safety is a factor and in areas used for warewashing other than the area behind the bar. |

2. Light bulbs must be shielded, coated, or otherwise shatter-resistant in areas where there is exposed food; clean equipment, utensils, and linens; or unwrapped single-service and single-use articles.

3. *Shielded, coated, or otherwise shatter-resistant bulbs need not be used in areas used only for the storing of food in unopened packages, if: the integrity of the packages cannot be affected by broken glass falling onto them; and, the packages are capable of being cleaned of debris from broken bulbs before the packages are opened.*

16. INSECT AND RODENT CONTROL

1. Devices that are used to electrocute flying insects must be designed to have escape resistant trays.
2. Devices that are used to electrocute flying insects and that impel insect parts or insect fragments or to trap insects by adherence must be installed so that the device is not located over a food preparation area and dead insects and insect fragments are prevented from being impelled onto or falling on exposed food, clean equipment, utensils, linens and unwrapped single-service and single-use articles.
3. Openings to a food establishment to the outdoors must be protected against the entry of insects and rodents by:
 - a. Filling or closing holes and other gaps along floors, walls and ceilings;
 - b. Providing closed, tight-fitting windows; and
 - c. Providing solid, self-closing, tight-fitting doors.
4. If windows or doors are kept open for ventilation or other purposes, the openings must be protected against the entry of insects and rodents by:
 - a. Providing screens made from 16 mesh to 1 inch (25.4 mm);
 - b. Properly designed and installed air curtains; or
 - c. Other effective means.
5. Perimeter walls and roofs of a food establishment must effectively protect the establishment from the weather and the entry of insects, rodents and other animals.

17. VENTILATION

1. All rooms must have sufficient tempered make-up air and exhaust ventilation to keep them free of excessive heat, steam, condensation, vapors, obnoxious or disagreeable odors, smoke, and fumes.
2. Ventilation hood systems and devices must be sufficient in number and capacity to prevent grease or condensation from collecting on the walls and ceilings.
3. Ventilation hoods must be installed in accordance with local building codes, the Uniform Mechanical Code (Minn. Rules Chapter 1305 & 1346) and the Minnesota Fire Safety Code (Minn. Rules Chapter 7510).
4. Ventilation exhaust hoods must be constructed of materials that meet N.S.F. Standard No. 2.
5. All open sides of the ventilation hood must overhang equipment by at least 6 inches.
6. Heat generating devices must be provided with a ventilation hood. The *Minnesota Commercial Kitchen Ventilation Guidelines*, written by the Ventilation Committee of the Inter-Agency Review Council, suggests that any device with a BTU output of 12,000 BTU/Hour (3.7kW/H) generates enough heat to require a ventilation hood. This is a cumulative standard. For example, two pieces of equipment are installed in a food service establishment. Equipment A has an output of 2.1kW/Hour and the Equipment B has an output of 1.8kW/Hour. Both pieces of equipment by themselves would not require ventilation. But, if both pieces are installed in the same establishment, the cumulative output would be 3.8kW/Hour and would require a ventilation hood.

The *Minnesota Commercial Kitchen Ventilation Guidelines* can be found at <http://www.health.state.mn.us/divs/eh/iarc/ventguide.pdf>

7. Filters, or other grease extracting equipment, used in a ventilation hood must be designed to be readily removable for cleaning and replacing if not designed to be cleaned in place.
8. Exhaust ventilation hood systems in food preparation and warewashing areas, including hoods, fans, guards, ducting, and other components, must be designed to prevent grease or condensation from draining or dripping onto food, equipment, utensils, linens, and single-service and single-use articles.
9. Mechanical warewashing machines must be provided with a Type II Ventilation hood.

A. Make-Up Air

1. Make-up air units must be installed in conjunction with ventilation exhaust hoods to replace air at the same rate that the air is being exhausted so as to not place the room under too great a negative or positive pressure.
2. A balance test performed by a qualified heating and ventilation professional must be conducted to demonstrate that the establishment has a well balanced ventilation system throughout the entire building while the ventilation hood exhaust fan(s) is operational during closed building conditions. The balance test should show that the building pressure is slightly negative between 2.0 - 5.0 Pascals

18. MINNESOTA CLEAN INDOOR AIR AC0054

1. Beginning October 1, 2007 smoking is prohibited in all indoor public places including restaurants and bars.
2. No Smoking signs must be posted at all entrances including employee entrances.
3. Outdoor smoking structures require approval prior to use.
4. For additional information:
<http://www.health.state.mn.us/freedomtobreathe/>

INDEX

A

ANSI, 12

B

Bars, 15

- Handwashing Sinks, 23
- Interior Surfaces, 15
- Utility Service Lines, 15
- Wooden Bar Tops, 15

C

Cabinet/Counter Construction, 17

Clean Indoor Air Act, 38

Clean-In-Place Equipment, 17

Condensate water, 10

D

Dipperwells, 15

Drainboards, 14

Dressing Rooms, 25

Dry Storage, 21

- Sizing Dry Storage, 21
- Space Required, 21

E

Edison Testing Laboratory, 12

Equipment, 12

- Custom Equipment, 15
- Specification Sheets, 5
- Used Equipment, 12

F

Field Changes, 6

Fingernail Brush, 15

Finishes, 19

- Carpeting, 20
- Ceilings, 19
- Coving Tile, 20
- Floors, 19
- Mats and Duckboards, 20
- Studs, joists and rafters, 20
- Walls, 19

Floor-Mounted Equipment, 14

Food Prep Area, 11, 14

Food Prep Sink, 14

H

Hand Soap, 15

Hand Towels, 15

Handwashing Facilities, 23

- Location, 23
- Number Required, 23
- Self-Closing Faucets, 23
- Supplies, 23
- Waste Receptacle, 23
- Water Temperature, 23

L

Lighting, 34

- Intensity, 34
- Shielding, 34

Lockers, 25

M

Make-up air, 37

Menu, 5, 7

Minnesota Department of Health, 27

Minnesota Food Code, 4

N

National Sanitation Foundation, 5, 11, 12, 16, 22, 28, 30, 36

P

Pest Control, 35

- Control Devices, 35
- Entry, 35

Plumbing, 27

- Air Break, 30
- Air Gap, 29
- Backflow, 29
- Backflow Prevention Device, 29, 30
- Control Valves, 30
- Cross-Connections, 29
- Design, 27
- Floor Drains, 10, 29
- Hand Washing Sink(s), 15
- Indirect Waste, 29
- Minnesota Plumbing Code, 5, 26, 27
- Plumbing Plans, 27
- Service Sink, 28

Potentially Hazardous Food, 7, 8, 15

Q

Quick Disconnect Gas Hoses, 30

R

Refrigeration, 8

- Point-of-use refrigerators, 8
- Rail Refrigerators, 10
- Reach-In Refrigerators, 9
- Salad bar units, 10
- Sizing, 8**
- Sizing Walk-In Refrigeration, 8
- Walk-In Refrigeration, 10

S

Salad Bars, 15

Sewage, 28

- Grease Trap, 29
- Individual Sewage Treatment System, 28
- Minnesota ISTS Code, 28
- Public Sewage Treatment Plant, 28
- Washington County ISTS Code, 28

Shelving, 22

Smoking, 38

- Freedom to Breathe Act, 38
- Outdoor Smoking Structures, 38
- Signage, 38

Sneeze Guards, 11, 15

Solid Waste, 33

- Drain Plugs, 33
- Exterior Receptacles, 33
- Exterior Refuse Storage Area, 33
- Hand Washing Sinks, 33
- Interior Refuse Storage Area, 33
- Receptacles, 33
- Toilet Rooms, 33

T

Table-Mounted Equipment, 13

Temperature Danger Zone, 7
Temperature Measuring Device, 10

Toilets, 26

- Number Required, 26
- Self Closing Door, 26
- Toilet Room Enclosed, 26
- Waste Receptacle, 26

U

Underwriters Laboratory, 12

Utility Service Lines, 30

V

Ventilation, 36

- Balance Test, 37
- Heat Generating Devices, 36
- Hood Filters, 36
- Hood Size, 36
- Minnesota Fire Safety Code, 36
- Uniform Mechanical Code, 36

W

Wait Stations, 16

Warewashing, 31

- Drying Rack Space, 32
- Flow Pressure Gauge, 31
- Mechanical Warewashers, 31
- Sanitizer Alarm, 32
- Space for Clean Equipment, 32
- Temperature Measuring Device, 31
- Ventilation Hoods, 32

Water Supply, 27

- Drinking Water, 27
- Non-Drinking Water, 28
- Public Water Supply Code, 27
- Water Treatment Systems, 28
- Well Code, 27